

Applications

1. Industry machinery power/motor control, Circuit insulation, Circuit protection and safety.
2. Vehicle battery distribution and back-up.
3. Inverter power control.
4. Power charging systems control.
5. Solar power plant.
6. Other DC high-voltage power control.



Product Factors

1. Hermetically **sealed with epoxy**, filled with **inactive gases** inside of contactor room, combining the **magnetic blow-out**, make product be **smallest, lightest weight, lightest noise** and bearing **High current and voltage** power switching.
2. **Intrinsically safe**, operates in explosive/harsh environments with **no oxidation or contamination** of coils or contacts, that could assurance **contact resistance steadying**, at same time, protect the contacts from water and dirt.
3. **No position sensitive**
Lightly weight of moving parts with huge counter-force and affected lightly by gravity, can be mounted in any position for ease of installation.
4. **Designed to meet: GB/T14048.1、GB/T14048.4 (IEC60947) .**
5. **According with EU RoHS Instruction (2002/95/EC).**

Part Number System

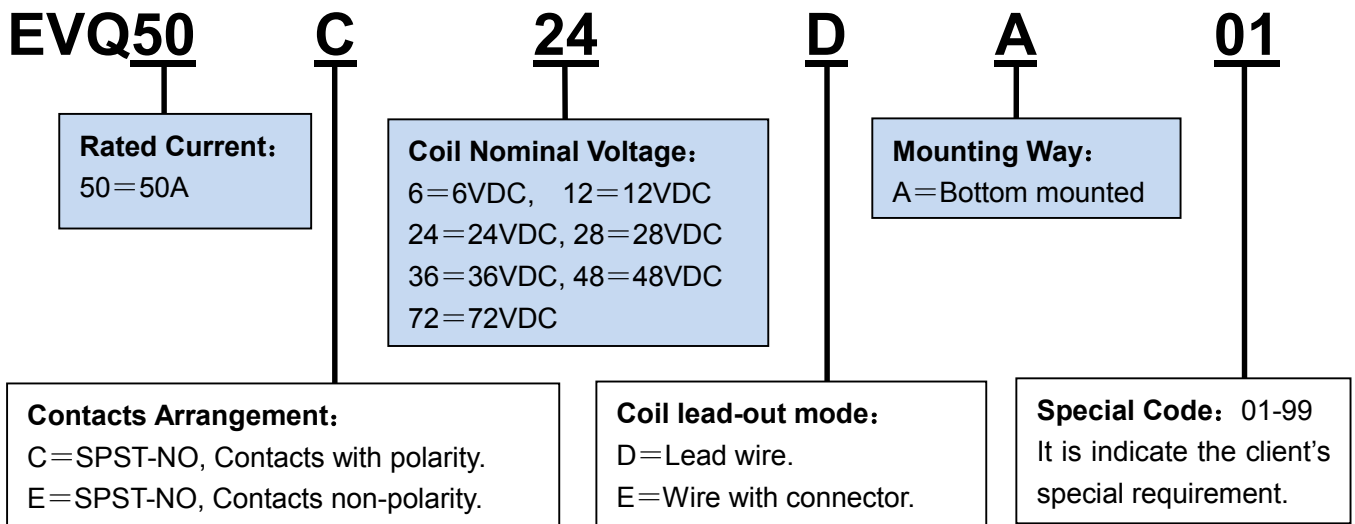

Note: The different connectors can be installed on the coil according to the client's requirement.

Coil Parameters

Nominal Voltage	Range of Working Voltage (at 20°C)	Pick-up Voltage (at 20°C) (▲1)	Holding Voltage (at 20°C)	Drop-out Voltage (at 20°C) (▲1)	Nominal Current (at 20°C)	Coil Resistance [±5%] (at 20°C) (▲1)	Coil Power (at 20°C)	Power-saving PCB	Coil Polar
6Vdc (Us)	Us85% Us110%	Us75% Max.	Us85% Min.	Us10% Min.	545.5mA	11Ω	3.3W	×	×
12Vdc (Us)	Us85% Us110%	Us75% Max.	Us85% Min.	Us10% Min.	266.7mA	45Ω	3.2W	×	×
24Vdc (Us)	Us85% Us110%	Us75% Max.	Us85% Min.	Us10% Min.	143.7mA	167Ω	3.45W	×	×
28Vdc (Us)	Us85% Us110%	Us75% Max.	Us85% Min.	Us10% Min.	116.7mA	240Ω	3.3W	×	×
36Vdc (Us)	Us85% Us110%	Us75% Max.	Us85% Min.	Us10% Min.	90.0mA	400Ω	3.2W	×	×
48Vdc (Us)	Us85% Us110%	Us75% Max.	Us85% Min.	Us10% Min.	76.2mA	630Ω	3.66W	×	×
72Vdc (Us)	Us85% Us110%	Us75% Max.	Us85% Min.	Us10% Min.	45.0mA	1600Ω	3.2W	×	×

▲1: Pick-up voltage, Drop-out voltage and Coil resistance of products without coil economizer may vary with ambient temperature and operating conditions. Therefore, please note that the following theoretical calculation formula can be obtained according to the temperature coefficient of copper resistance. The calculated value may be slightly different from the actual value.

Temperature rise: $\Delta T = U \times (1 + 0.004 \times K)$,

Temperature drop: $\Delta T = U \times (1 - 0.004 \times K)$,

where U = rated value at 20°C, K = current ambient temperature - 20.

Functional Data

Electric Types	Type		Contactor
	Contact Arrangement		SPST-NO-DM
	Current Type		DC
	Media type when cutting-off		Inactive gas
	Operation method		Electric driven
	Rating operation system		Uninterrupted Working System
	Auxiliary Contact (▲7)		×
Contact Parameters	Contact Polar	Polarity	✓
		Non-Polarity	✓
	Rating Voltage		12-900Vdc
	Rating Current		1-50A (▲2)
	Current Endurance		150A 30sec.
			250A 10sec.
	Break Current, Max, only 1 time		500A 320Vdc
	Contact Resistance		1mΩ Max. (at 1A)
	Operate Time (at 20℃)		25ms Max. (▲3)
	Bounce Time (at 20℃)		7ms Max. (▲3)
	Release Time (at 20℃)		12ms Max. (▲4)
Life	Mechanical Life		1×10 ⁶ cycles (▲6)
	Electrical Life (▲2,▲5)	Polarity	Graph-1
		Non-Polarity	Graph-2
Dielectric Parameters	Insulation Resistance		Initial state: 100MΩ Min. (▲1)
			End of life: 50MΩ Min. (▲1)
	Dielectric Strength	Between open	AC 2500 Vrms/1mA/1min. (Sea Level)
Between Contacts and		AC 2500 Vrms/1mA/1min. (Sea Level)	
Mechanical Parameters	Shock, 1/2sine, 11ms		Peak ,20G (Coil energized)
	Vibration ,sine, 80~2,000Hz		Peak ,20G
Condition	Operating Ambient Temperature		-40℃~+85℃
	Operating Ambient Humidity		5%~95% RH.
Weight			120±10g
Security Certification			CE、CCC、UL

▲1: Measurement voltage DC1000V with the same test position as dielectric withstand voltage.

▲2: Resistive Load, L/R≤1ms.

▲3: Coil nominal voltage, includes bounce.

▲4: Coil nominal voltage, without diode.

▲5: Switching Rating, ON : OFF=1s : 9s.

▲6: Switching Rating, ON : OFF=0.5s : 0.5s.

▲7: Auxiliary Parameter, Ith: 3A, AC -12: 125V/3A; DC -12: 30V/2A.

Estimated Electrical Life

Make & Break Switching Rating (Resistive Load L/R≤1ms, ON: OFF=1Sec:9Sec)

Graph-1, EVQ50 Series (Polarity)

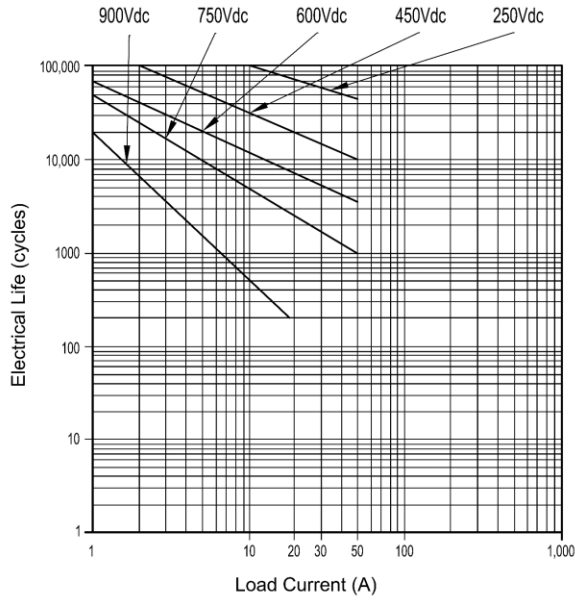

Graph-2, EVQ50 Series (Non-Polarity)

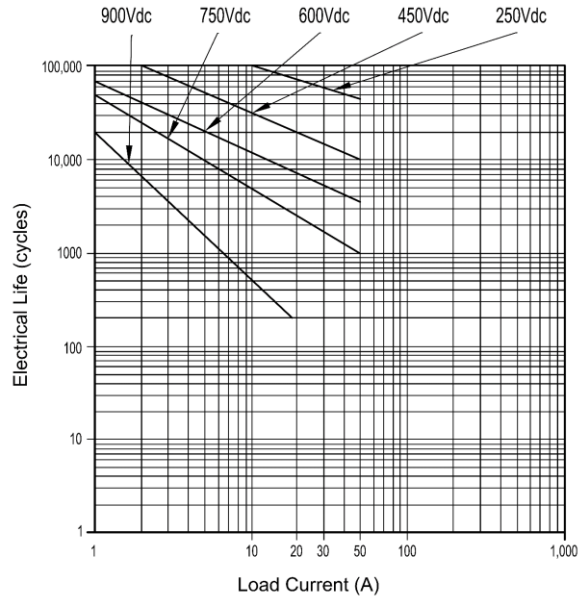

Estimated carrying current endurance

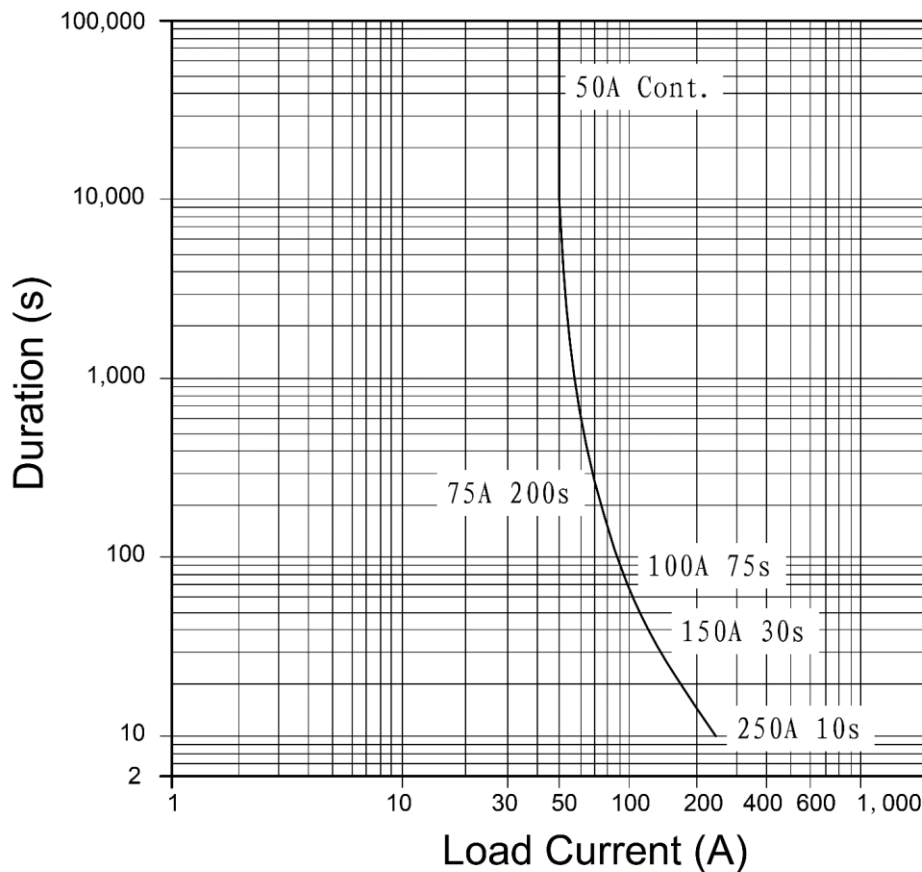

Dimensions

Outside Dimensions:

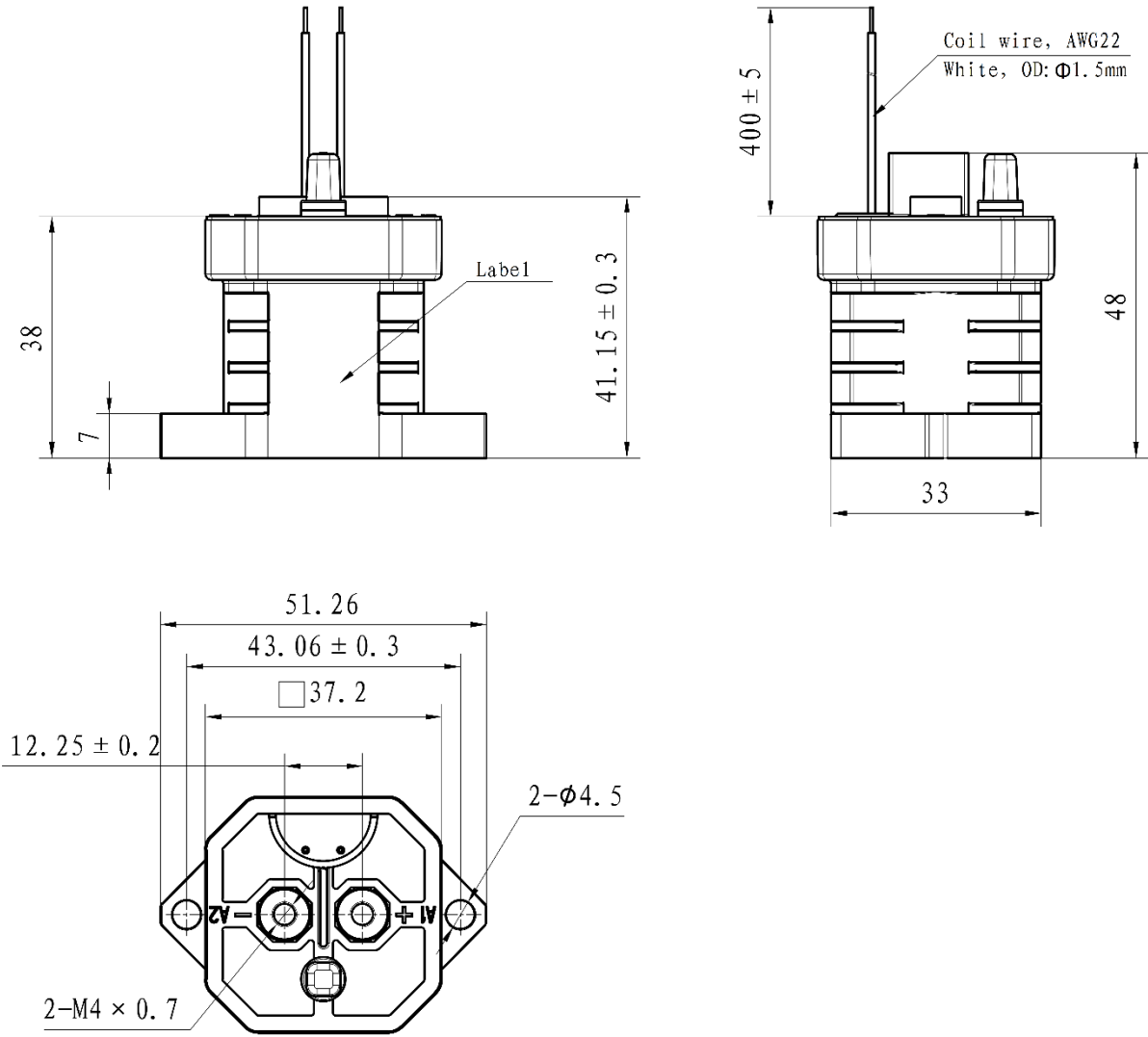

Wiring Graph:

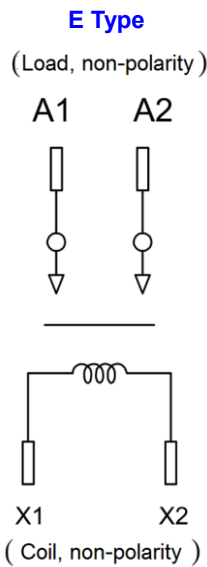
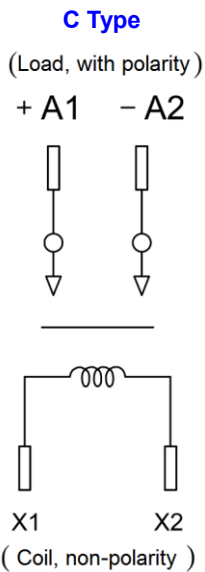

Annotation:

- Unit: mm
Visual Angle:
- Tolerance(not specified):
<10mm: ±0.3
10~50mm: ±0.6
>50mm: ±1.0
- Coil wire length and connectors could be customized according to client's requirement.

Installation

<p>Outside size (bottom area) Unit: mm</p>		
<p>Process graph of basic plate Unit: mm</p>		
<p>Shape of Main Contacts Unit: mm</p>		
<p>Fastener on main contacts</p>	<p>Specification Unit: mm</p>	<p>M4x8</p>
	<p>Provide or not</p>	<p>✓</p>
<p>Torque range</p>	<p>Bottom of contactor</p>	<p>1.8-2.5Nm</p>
	<p>Main contacts</p>	<p>1.8-2.5Nm</p>
<p>Nominal section area of conductor</p>		<p>15mm² Min.</p>

Notes

1. Please use the washer to prevent loosening when contact installation. Screw locking torque should be in specified range, damage may occur when it is beyond.
2. The contactor has two types of contacts, polarity and non-polarity, there are +A1 and -A2 marks on cap of product. Please follow the wiring graph to connect the wire (for current flows from +A1 to -A2), wrong connection may cause malfunction or abnormal heating.
3. Please note that there could be abnormal fever when using condition is beyond the specified rating value like coil rated, contacts rated and life and so on.
4. Please do not use the product when it has fallen down.
5. Please avoid installation in strong magnetic field (around the transformers or the magnets) and the heating objects nearby.
6. When installing multiple contactors adjacent to each other, please pay attention to the abnormal heating caused by heat interference and the insulation distance between the terminals outside the contactor.
7. Life time of the electricity
The contactor is high voltage DC switch, it will lose the breaking function during its final shocking module, therefore, it cannot be used by exceeding its breaking capacity and life-time parameter (please consider the contactor as the limited life-time product and change it when necessary). The surrounding components may be burnt while the contactor loses its breaking function. So, it is very important to design and protect the circuit properly and make sure the power can be cut within 1 second.
8. The spreading life-time of the inner gas.
The contactor adopts the sealed cabinet contacting point, there is gas inside of the cabinet, the gas life-time is decided by the temperature inside of the contacting room (environmental temperature + temperature produced by power setup on contacting point), therefore, the environmental temperature should be kept between -40 till +85°C.
9. The coil resistance will be increased due to the coil temperature goes up if the rated voltage (or current) setup continuously on the coil and the contacting point, thus, the operating and breaking voltage of the product go up, and the rated voltage may be exceeded or released. Under this condition, the following measurements can be taken: decrease the loading current and limit the continuous power setup time or, adopts the coil voltage higher than the rated ones.
10. The rating load of contact is resistive load. Please assure the surge absorption device together with inductive load when using the $L/R \geq 1\text{ms}$ inductive load (L Load), otherwise it may lead to the decrease of electrical life and defective switch.
11. Drive power must be more than coil power, or it will make product's break ability weaker.
12. Do wiring should be after power-off.
13. Contact resistance may rise when product switching with no load.
14. Please avoid grease or other foreign matter on the terminal, and make sure conductors are reliable contact with product's main terminals, otherwise, abnormal heating may occur at terminals.
15. When using capacitive load, it is need a pre-charge circuit to assure the impulse current less than contact's rating current, otherwise, it may cause main contacts welding.

Special Claim:

Because the performance is different from each other when it used in different applications, customer could choose the appropriate product according to the specific using conditions. If there is any queries, please contact JONVER for technical support.